



**HANGCHA GROUP CO., LTD.**

Factory site: 666 Xiangfu Road,  
Hangzhou, Zhejiang, China (311305)

Tel: +86-571-88926735 88926755  
Fax: +86-571-88926789 88132890

sales@hcforklift.com www.hcforklift.com

HANGCHA GROUP CO., LTD. reserves the right to make any changes without notice concerning colors, equipment, or specifications detailed in this brochure, or to discontinue individual models. The colors of trucks, delivered may differ slightly from those in brochures.



Follow us on Facebook



Follow us on YouTube



Follow us on WeChat



Download "Hangcha Forklift" App



ISO45001:2018



ISO14001:2015



ISO9001:2015



HANGCHA trucks conform to the European Safety Requirements.

# XH SERIES

HIGH-VOLTAGE TELEHANDLER

With capacity of 2,500 to 3,500kg

# XH SERIES HIGH-VOLTAGE TELEHANDLER

HANGCHA Family-Design exterior, ergonomic cab, intuitive HMI system and premium driving comfort experience.

## HIGH-PERFORMANCE MACHINES IN ANY SITUATION



With permanent magnet synchronous motor (PMSM) technology, can reach top speed: 25 km/h, maximum grade ability: 45%, and industry-leading performance in its class.

 **25 km/h**  
Drive speed (no load) |  **45%**  
Gradeability

### THREE STEERING MODES:

4-Wheel Crab Steer



2-Wheel Front Steer



4-Wheel Circle Steer



### TWO DRIVING MODES:

**2WD**  
TWO-WHEEL DRIVE

**4WD**  
FOUR-WHEEL DRIVE

The machine is equipped with quick change device, which can realize the quick replacement of different attachments. This enables various operations including fork loading, shovel loading, clamping, aerial work, etc.

The first compact telehandler with 310V high-voltage lithium battery in industry, high voltage DC fast-charging technology. Make a charge from 30% to 80% only in 30 minutes.

**310V**  
HIGH-VOLTAGE

Convenient charging solutions, two charging methods: DC fast-charging port and 10kW built-in charger.

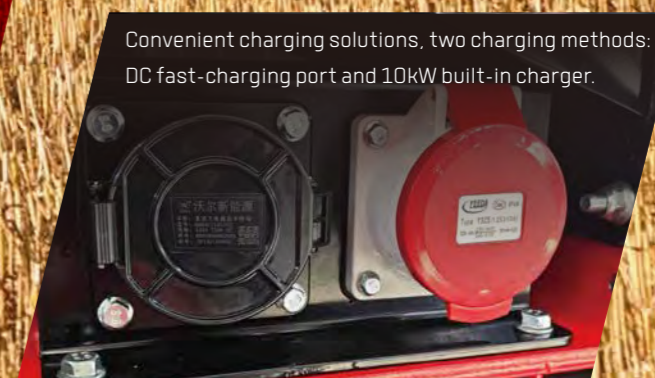

# COMFORT

## Driver assistance system and easy control

- 1 The cab can be equipped with air conditioning, radio, and USB charging port as option.
- 2 Adjustable suspension seat can provide more ergonomic.
- 3 Full-proportional joystick, smooth and coordinated movements, smooth and steady on start and stop, boom luffing and telescoping support multi-movements.
- 4 7 inch display, real-time machine status monitoring, integrated intelligent fault diagnosis system.



# SAFETY

- Lithium iron phosphate battery pack---high safety & proven reliability.
- The lighting system is excellent. Besides the High and low beam headlights, LED high-brightness working lights are also provided in the cab front and rear and the boom respectively, ensuring operation in night scenarios.
- Equipped with overload monitoring system, it can conduct real-time dynamic monitoring to prevent overturning and overloading, and timely restrict actions to avoid accidents.

# MAINTENANCE

- The machine is equipped with a maintenance arm to prevent the risk of accidental fall of the arm frame during maintenance.
- Wide-angle tilting cover ensures easy maintenance access.



## Technical data

		HANGCHA GROUP CO.,LTD.			
			T25-60XHYG	T35-100XHYG	T35-70XHYG
Lifting capacity	Manufacturer		HANGCHA GROUP CO.,LTD.		
	Model		T25-60XHYG	T35-100XHYG	T35-70XHYG
	Max. lift capacity	kg	2500	3500	3500
	Lift capacity at maximum height	kg	2000	2500	2500
	Lift capacity at maximum reach	kg	800	500	500
	Max. lifting height	mm	5800	9800	7300
	Max. forward reach	mm	3310	7000	4170
	Load centre distance	mm	500	500	500
	A Front overhang	mm	1000	1240	1260
	B Wheelbase	mm	2300	2750	2750
C Tread	mm	1500	1850	1850	
D Overall length	mm	3950	5030	5050	
E Fork length	mm	1070	1200	1200	
F Overall height	mm	2020	2350	2350	
G Overall width	mm	1820	2300	2300	
H Cabin width	mm	810	940	940	
J Min. Ground clearance	mm	240	400	400	
K1 Tilt-up angle	°	12	12	12	
K2 Tilt-down angle	°	117	116	116	
L Min. turning radius	mm	3300	3700	3700	
Weight	kg	5500	9600	9200	
Dimensions and Weight	Tyre type		Vacuum tire	Vacuum tire	Vacuum tire
	Tyre size		12-16.5-14PR /2	400/80-24	400/80-24
	Drive wheel x Steering wheel		4x4	4x4	4x4
	Frame leveling Angle	°	--	9	9
	Boom lower/raise angle	°	-2/68	-3.5/62	-3.5/62
	Boom raising time (no load)	s	11	15	15
	Boom lowering time (no load)	s	8	10	11
	Extension time (no load)	s	9	17	11
	Retract time (no load)	s	9	16	13
	Fork backward time (no load)	s	4.5	6	6
Fork forward time (no load)	s	4.5	6	6	
Frame leveling time (side to side)	s	/	10	10	
Max. travel speed (no load)	km/h	25	25	25	
Max. Drawbar pull	N	35000	50000	50000	
Gradeability	%	45	45	45	
Wheels	Drive motor power	kW	30	45	45
	Pump motor power	kW	35	35	35
	System voltage	V	310	310	310
Performance parameters	Battery capacity	Ah	150	173	173
	Power	kWh	46	53	53
	Charger output power 1P220V	kW	3	3	3
	Charger output power 3P380V	kW	10	10	10
	Motor parameters				
Power parameters					

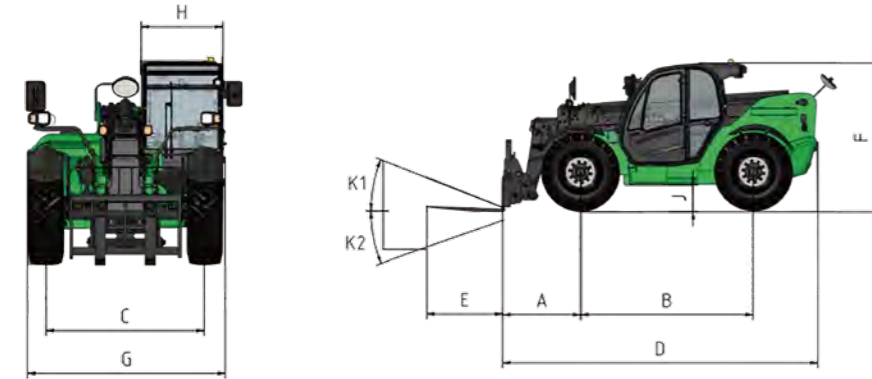
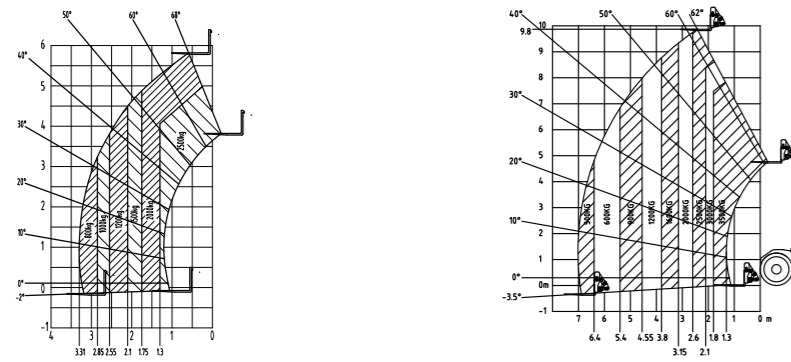

## Features

Truck	Standard	Options
Air conditioner		○
Reverse radar		○
Rotating Amber beacon		○
Fire extinguisher in cabin or at rear		○
Rear Camera + Monitor		○
Quick exchange fork carriage	●	
Load backrest	●	
Adjustable suspension seat	●	
Flame retardant leather seats	●	
Traction device	●	
Load moment limiter Overload monitoring devise	●	
Left operable window	●	
Horn	●	
Key switch	●	
Wide angle L/R rearview mirrors	●	
Panoramic reversing mirror	●	
Front wiper with water spray function	●	
Rear window wiper	●	
High and low beam headlights	●	
Front and rear work lights	●	
Working light	●	
Reverse light	●	
Windshield protective frame		○
Fire Extinguisher		○
Foam filled tire		○
Quick change heavy Duty Multi-Purpose Bucket		○
Quick change soft bale clamp		○
Quick change crane arm		○
Forklift arm		○
<b>Steering</b>		
Three steering modes	●	
Adjustable steering column	●	
<b>Hydraulic</b>		
Hydraulic quick coupler	●	
Tilt cylinder self-locking valve	●	
Self locking valve for telescopic oil cylinder	●	
Lifting cylinder self-locking valve	●	
Lifting cylinder maintenance arm	●	
Hydraulic Oil Filter	●	
Hydraulic oil air filter	●	
Hydraulic oil dipstick	●	
<b>Power</b>		
2WD and 4WD switch function	●	
Three gears	●	
<b>Transmission</b>		
Wet brake	●	
Limited slip differential	●	
Hydraulic power steering	●	
<b>Control</b>		
Dual axis proportional control handle	●	
Emergency stop switch	●	
Parking brake	●	
<b>Safety</b>		
Warning light	●	
Reverse alarm	●	
Reverse camera		○
Reverse radar		○
<b>Accept various attachments</b>		
Fork-Mounted Extendable Truss		○
Fork-Mounted working platform		○
Bucket		○
Truss boom		○

Electronics	Standard	Options
Build-in charger	●	
DC fast charging port	●	
Fault self diagnosis function	●	
7-inch color multifunctional display screen	●	
Motor temperature display	●	
Warning lamp for not fastening the seat belt	●	
Water cooling system	●	
Heater	●	
Reading light	●	
Radio	●	
USB charge port	●	

